

ACOUSTIC ZONING

Verta Modular Acoustic Zoning

Verta is a versatile system of vertical acoustic baffles designed to help you zone space, enhance comfort and bring visual softness to commercial interiors. Made from GRS-certified fibres containing 99% recycled content, Verta combines sustainable materials with a refined architectural aesthetic.

Flexible by Design

Fixed Bulkhead System

- A ceiling-mounted bulkhead and base plate allow baffles to simply slide in and drop down, delivering a clean, integrated finish for more permanent zoning
- Available in four height options
- Modular by design, four vertical baffles in each standard module
- Bespoke options available on request

FEATURES

- ▶ Available in easy to install mounting option
- ▶ Four different height options
- ▶ Modular by design for enhanced creative flexibility
- ▶ Made using GRS-certified fibres containing 99% recycled content
- ▶ Available in 45+ nature inspired colours and 9 different wood and concrete finishes
- ▶ No formaldehyde binders
- ▶ Low VOCs
- ▶ Not affected by moisture, mould or mildew
- ▶ EN 13501-1:2018-B, s1, d0; ASTM E84 -16 - Class A
- ▶ CAD files available to download from our website
- ▶ Declare Labelled Red List Free

Available in 45+ colours and 9 different wood and concrete finishes, Verta offers extensive design freedom—allowing you to blend, contrast or create standout acoustic features with ease.

Verta provides effective sound control without blocking light or airflow, helping you create flexible, comfortable, human-centred environments. Designed for modern workplaces, education spaces and hospitality settings, it's an acoustic solution that works as hard as it looks good.



Verta Modular Acoustic Zoning

CODE	DESCRIPTION	DIMENSIONS (mm)
VERTA-24	Verta Baffles 2400m	2400H x 800W x 250D
VERTA-26	Verta Baffles 2600m	2600H x 800W x 250D
VERTA-28	Verta Baffles 2800m	2800H x 800W x 250D
VERTA-30	Verta Baffles 3000m	3000H x 800W x 250D

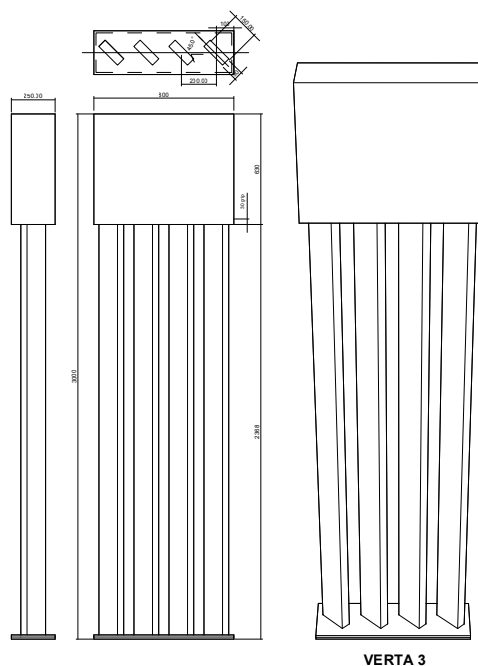
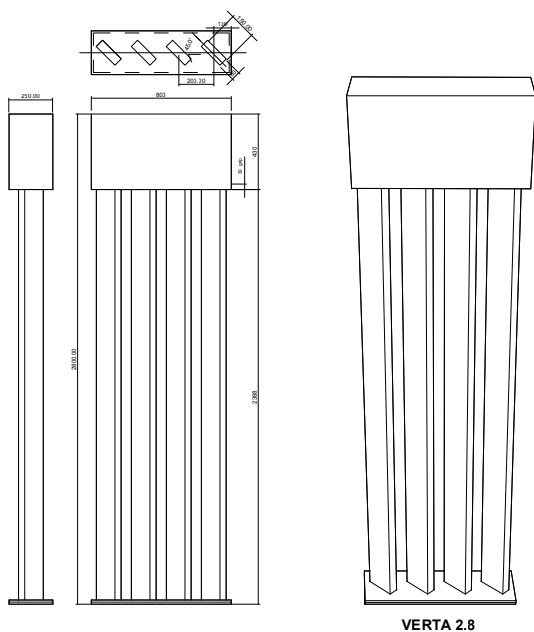
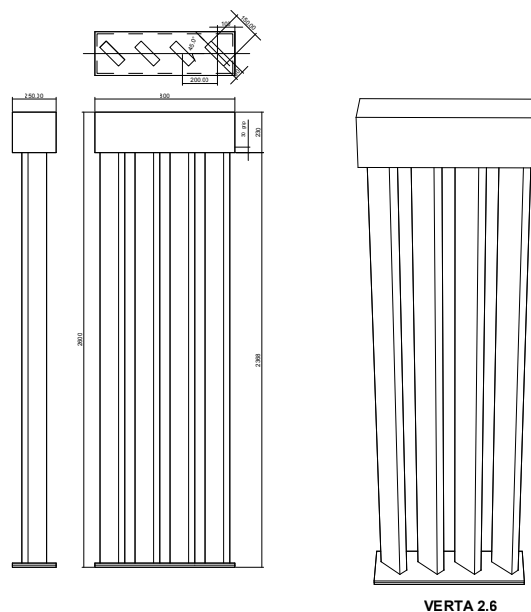
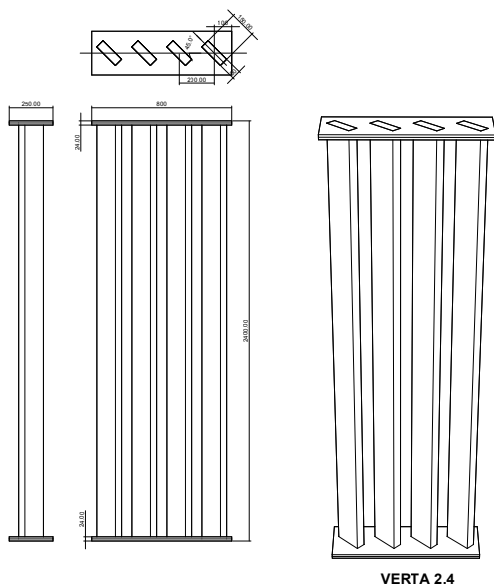

SENSE WOODGRAIN FINISHES

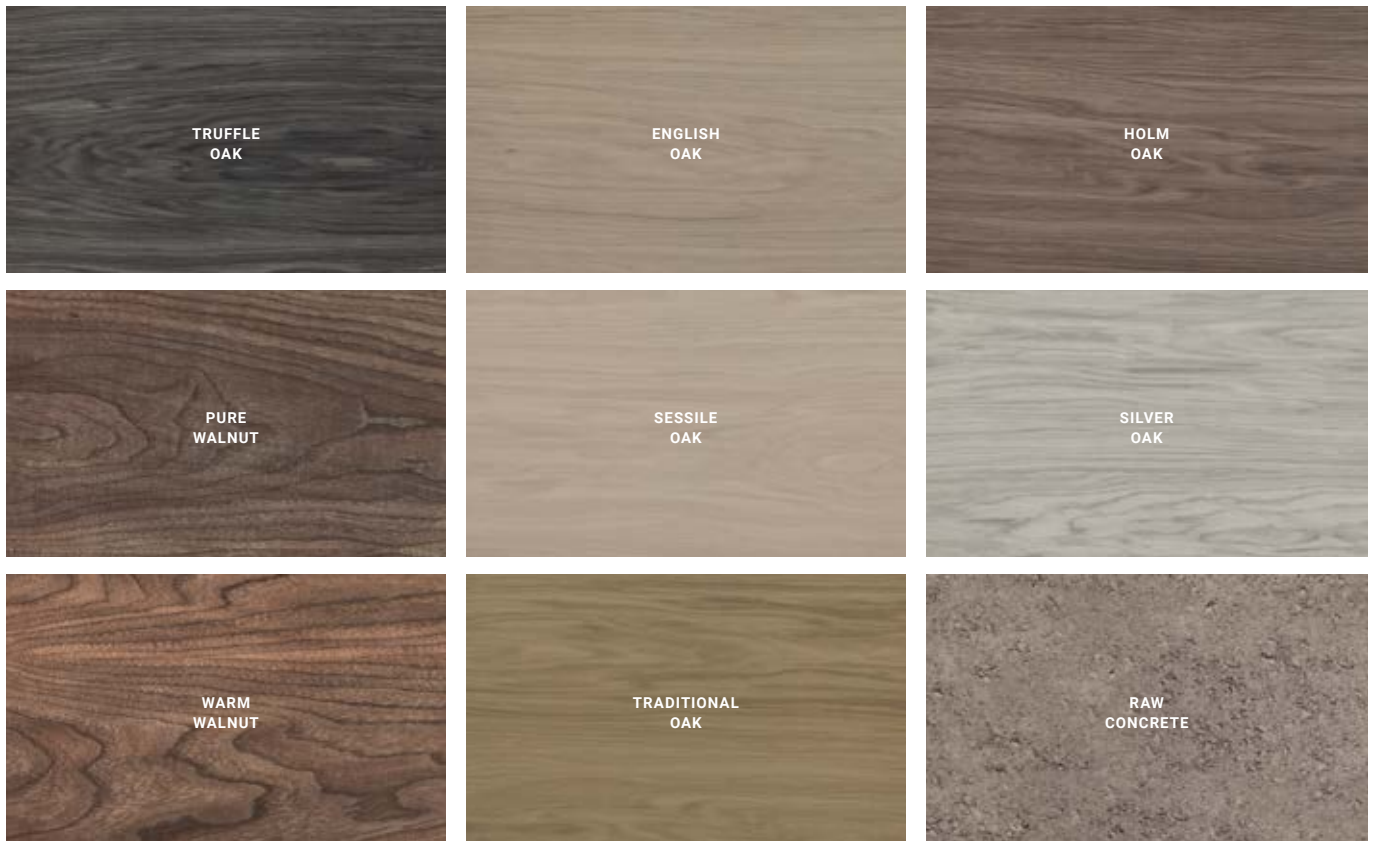

ÖRA COLOURS*



REJUVENATE PALETTE



REFINE PALETTE



REFRESH PALETTE

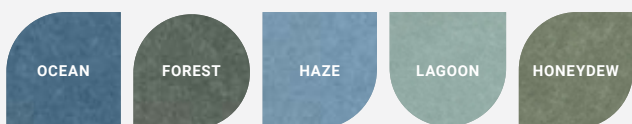

* Please include the felt colour you require with your request.

Care Instructions

Our products are extremely durable and require little attention to maintain their good looks. Light dusting on a regular basis will prevent dust build up and most marks can be cleaned with a mild detergent solution followed by rinsing and blotting. Stains should be dealt with according to the chart below.

Before carrying out a proposed cleaning method, apply to a concealed section to ensure it will not affect the product or adhesive. Avoid cleaning methods that create severe abrasion. NB: Solvent and mineral based cleaners should be used sparingly to avoid possible degradation of the adhesive adhering the product to the substrate.

Professional Cleaning Methods

Stain	Treatment Guide
Blood	A, C
Burn/Scorch Mark	K
Chewing Gum	I, B, D, C
Chocolate	B, D, C
Cooking Oils	B, D, C
Crayon/Colour Markers	B, D, C
Drinks	A, C
Dust/Dirt	Vacuum, then J or C
Excrement	B, C
Grass	C
Grease	B, D, C
Ink (ballpoint)	D, E
Ink (fountain)	A, C
Lipstick	B, E, C, D
Mildew	C
Milk	A, E
Mud	B, C
Nail Polish	A, G
Oil	B, D, C
Paint (water based)	A, F, C
Paint (oil based)	A, H, D, C
Sauces	B, C, D
Shoe Polish	B, C, D
Urine	A, C
Vomit	A, C, D
Wine	A, Add Salt, C

Key

- A** Mop up excess as soon as possible with a sponge or cloth.
- B** Remove surplus with a knife edge or appropriate instrument.
- C** Sponge with a solution of carpet shampoo working from well outside the stain in a circular motion towards the centre (this avoids spreading the stain). Sponge afterwards with clean warm water and mop excess moisture with a clean dry cloth or sponge. Allow to dry then brush gently with a soft brush. If any stain remains, sponge with a solution of one part household bleach to six parts clear water. Thoroughly rinse after treatment.
- D** Lightly sponge with household dry cleaning fluid and blot. Apply sparingly, as the substance may have an adverse effect on the adhesive.
- E** Sponge with methylated spirits and blot dry.
- F** Lubricate the stain with glycerine or petroleum jelly.
- G** Apply nail polish remover. The nail polish remover should not include lanolin or be of a greasy nature.
- H** Sponge with turpentine (or substitute).
- I** Freeze with ice cubes and scrape away while cold.
- J** Clean with regular extractive carpet cleaner (if possible).
- K** Use circular cutter and remover damaged portion. Re-glue new piece into place.

Please contact us for a detailed installation guide.

Showroom: 14 Baltic Street East, London, ECIY 0UJ

Head Office and Factory: Aspect Gate, 1 Olds Approach, Watford, WD18 9RF

www.allsfar.com • +44 (0)20 3889 9888 • hello@allsfar.com



ALLSFÄR